

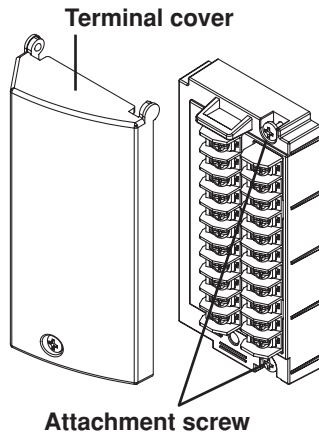

User's Manual

MX100/MW100 Handling of the Plate with Screw Terminals (772080)

Names of parts



External dimensions (Unit: mm)

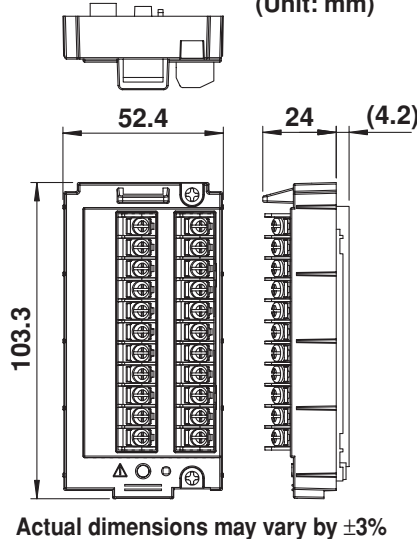

Terminal arrangement markings

1	2 CH6	1	2 CH1
3	4 CH7	3	4 CH2
5	6 CH8	5	6 CH3
7	8 CH9	7	8 CH4
9	10 CH10	9	10 CH5
11	11 RTD	11	11 RTD

Note: The b terminal is common to all channels. The b terminals are connected internally.

Supported input modules

- 10-CH, Medium-Speed Universal Input Module (MX110-UNV-M10)
- 10-CH, Pulse Input Module (MX114-PLS-M10)
- 10-CH, High-Speed Digital Input Module (MX115-D05-H10, MX115-D24-H10)

Attaching the Plate with Screw Terminals

With the /NC option, begin from step 3.

1. Loosen the terminal cover attachment screw, then flip up the terminal cover in the direction of the arrow as shown in the figure.
2. Loosen the terminal plate screw, then remove the clamp terminal plate.
3. Attach the screw terminal plate, then fasten with the screw.
4. Attach the terminal cover that came with the screw terminal plate.

Terminal cover (standard accessory)

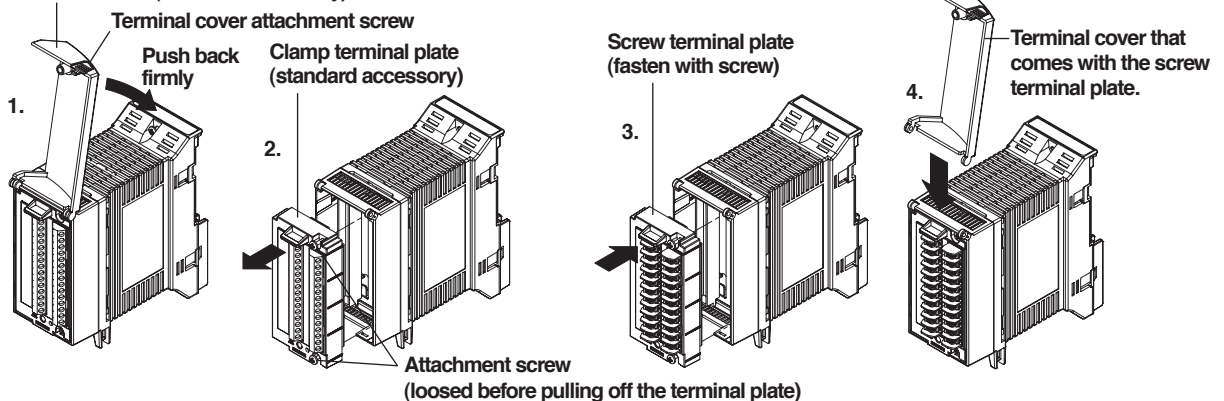

Note

The 10-CH, Pulse Input Module is compatible with the MW100.

Notes on Wiring and Calibration

When connecting the screw terminal plate, note that the terminal arrangement is different than that of the clamp terminals.

Also, the PC software recognizes the screw terminals as clamp terminals, meaning that the module icons, calibration software wiring diagrams, and other displays show the wiring for the clamp terminals.

Therefore when wiring and performing calibration, you must follow the markings showing the terminal functions and the terminal codes indicating the types of signals input to each terminal located on the back of the terminal cover of the 10-CH screw terminal plate.

General Precautions When Wiring the Input Signal Wires



WARNING

- To prevent the possibility of electric shock when wiring, confirm that the power supply source and signal source are turned OFF. After making the connections, secure the terminal cover and do not touch the terminals with your hands.
- For signal wires on which voltage exceeding 30 VAC/60 VDC is applied relative to the ground potential or between signals, use double (reinforced) insulation wires. For all other signal wires, use basic insulation wires. For the withstand voltage of insulation wires, see the table below.

Applied Voltage (Vrms or VDC)	Basic Insulation	Double (reinforced) Insulation
30 (60 VDC) to 100	620 Vrms	1000 Vrms
101 to 150	840 Vrms	1400 Vrms
151 to 300	1390 Vrms	2300 Vrms
301 to 600	2210 Vrms	3700 Vrms

- When wiring the screw terminal plate, attach the screw terminal plate to the input modules before inputting signals. Electric shock or fire can result if signals are applied to the terminals when the screw terminal plate is removed from the input modules.
 - When wiring to screw terminal plate, use round, insulation coated crimp-on lugs (for 3-mm screws) on the terminals that do not come out when loose. The appropriate screw tightening torque is 0.6-0.7 N·m.
 - To prevent fire, use signal wires with a 80°C or higher temperature rating.
-



CAUTION

- If a large pulling force is applied to the input signal wires connected to the MX100 and MW100, the terminal or signal wire may break. To prevent this from happening, secure all the wiring cables to the installation panel.
 - Do not apply a voltage exceeding the value indicated below to the input terminals of the 10-CH, Medium-Speed Universal Input module. Doing so can damage the modules.
 - Maximum input voltage
Voltage range of 1 VDC or less, TC, RTD, and DI (contact): ± 10 VDC
Voltage range of 2 VDC or more, and DI (LEVEL): ± 120 VDC
 - Maximum common mode voltage
Between channels: 120 VACrms (50/60 Hz)
Input to ground: 600 VACrms (50/60 Hz)
 - Do not apply a voltage exceeding the value indicated below to the input terminals of the 10-CH, Pulse Input module and 10-CH, High-Speed Digital Input modules. Doing so can damage the modules.
 - Maximum input voltage
10-CH, Pulse Input module and 10-CH, High-Speed Digital Input module:
 ± 10 VDC (Pulse input and digital input (-D05)), ± 50 VDC (digital input (-D24))
 - Maximum common mode voltage
Input to ground: 250 VACrms (50/60 Hz)
 - When using the pulse input module with contact input, the measured signal becomes easily affected by wiring impedance at high speed. The cable should be approximately 25 m or less when the pulse width is 0.05 ms, or 500 m or less at 0.5 ms. The wiring impedance varies depending on the such things as the cable length, type, and wiring conditions.
 - The MX100 and MW100 are a measurement category II (IEC61010-1) and overvoltage category II (CSA1N.61010-1) instrument.
-

Wiring Procedure, Specifications, and Other Items Related to the Input/Output Modules

See the MX100/MW100 Data Acquisition Unit Installation and Connection Guide (IM MX100-72E) provided with the main module, or the MX100 Data Acquisition Unit User's Manual (IM MX100-01E) or the MW100 Data Acquisition Unit User's Manual (IM MW100-01E) contained in the manual CD-ROM.
